

Ingenuity in
infection control
since 1830



PG 8581 Washer Disinfector

Site Preparation Plan

Important: Please complete the Site Preparation Statement inside this manual to begin your washer disinfector installation.

Thank you for choosing Eschmann

Eschmann design, manufacture and supply a range of market leading products including benchtop autoclaves, accessories, washer disinfectors and surgical suction.

For further information visit our website: www.eschmann.co.uk.

About this Site Preparation Plan

Please read this Site Preparation Plan before installing or using the product for the first time. Keep the manual handy for quick reference. Always make sure that the manual is available for the next user/owner of the product.

The product(s) described in this manual must only be operated and used by medically qualified personnel trained in the use of this equipment. Contact Eschmann with your training requirements.

Pay particular attention to the safety notes, cautions and warnings provided in the text, and also to those displayed on the product labels.

This product must be installed in accordance with the procedures given in this manual. Failure to do so could result in injury to patients and/or users, or damage to the equipment.

Confirm the service interval for the product. Eschmann products must be serviced and maintained by Eschmann trained engineers only. Failure to do so may invalidate the warranty.

Contents

Site Preparation Statement	4
1 Choosing a Location	5
1.1 Requirements	5
1.2 Considerations	5
1.3 PG 8581	6
2 Contractor Notes	7
2.1 Electrical Notes	7
2.2 Plumbing Notes	7
3 PG 8581: 32A 230V Single Phase Installation	8
4 PG 8581: 400V 3 Phase Installation	9
5 Optional Equipment	10
5.1 Autolog (8701027)	10
5.2 RS232 Printer (8721367)	10
5.3 Eschmann RO Water System	10
5.4 RO/DI Water Supply (third party system)	10
6 Containers	11
6.1 Rinsing Aid	11
6.2 Detergent	11

Actions Required

Prepare the installation site to meet ALL of the requirements in this Site Preparation Plan

- 1 Read and understand this manual. Obtain technical advice if required.

1 If there are problems with the site preparation or the site services, an engineer's visit will be charged at the normal rate.

- 2 Provide a cupboard or space next to the unit for all the electrics and pipe work. Read sections 3 & 4 for the minimum width required. **Sections 1, 3, 4**

- 3 Ask your contractor to source the necessary site termination discussed in section 2. **Section 2**

- 4 Before the contractors start work, tell them about any options being fitted:

 - RO/DI (Reverse Osmosis or De-Ionised) water supply, or other specialist water supply (requires extra water and electrical supplies) **Section 5**
 - Printer or Autolog

- 5 The contractors must follow the plans **exactly** and install:

 - Electrical supplies and power points **Sections 2, 3, 4**
 - A mains cold water supply **Sections 2, 3, 4**
 - A separate water drainage connection point **Sections 2, 3, 4**
 - Optional separate RO/DI water supply connection point **Sections 1, 3, 4**
 - Prepare all cut-outs and holes in work tops and cupboards as required **Sections 1, 3, 4**

- 6 When you are sure that the site is ready, you and your contractor(s) MUST sign the Site Preparation Statement and email or post it to Eschmann. (The address is at the bottom of the Site Preparation Statement). **Site Preparation Statement**

On receipt of the certificate, we'll arrange a mutual date to install your Washer Disinfector. We'll also send you a free sample of the recommended detergent to use during installation.

WARNING!

All electrical and plumbing work must be carried out by suitably qualified and competent persons in accordance with local and national safety regulations.

CAUTION

This Washer Disinfector should only be installed and maintained by an Eschmann Service Engineer. Repairs and other work by unqualified persons could be dangerous.

We recommend using a WRAS approved plumber (Water Regulations Advice Scheme). Visit their website "www.wras.co.uk" for details.

We recommend using an NICEIC approved electrician. Visit their website "www.niceic.org.uk" for details.

Site Preparation Statement

The site preparation has now been completed in accordance with the 'Site Preparation Plan' reference MUW216742. Please make arrangements to Install the Washer Disinfector on a mutually agreeable time and date. Contact details have been entered below. I am aware that should the site preparation not be to the required standard, or is in any way not suitable for installing the Washer Disinfector upon the arrival of the Eschmann Service Engineer, I will be liable for the standard cost of an Engineer's call out charge. By signing this certificate below I am accepting this charge should it be incurred.

Electrical site preparation (To be signed by Electrical Contractor)

I hereby certify that the electrical site preparation for the Washer Disinfector has been carried out in accordance with the 'Site Preparation Plan' reference MUW216742. I also certify that all the site installation work complies with all National and Local Legislation current at the time the work was carried out. For and on behalf of:

Company Date
Address
E Mail Tel. No.
Name (block capitals please) Signed

Plumbing site preparation (To be signed by Plumbing Contractor)

I hereby certify that the plumbing site preparation for the Washer Disinfector has been carried out in accordance with the 'Site Preparation Plan' reference MUW216742. I also certify that all the plumbing complies with all National and Local Legislation current at the time the work was carried out. For and on behalf of:

Company Date
Address
E Mail Tel. No.
Name (block capitals please) Signed

Site preparation approval (To be signed by the Customer)

I hereby certify that the plumbing, electrics and partition cut-out as detailed in Section 1 for the Washer Disinfector has been carried out in accordance with the 'Site Preparation Plan' reference MUW216742 and that the site is suitable for the installation and commissioning of the Washer Disinfector. I have read the Eschmann Guarantee in section 8 of the 'Site Preparation Plan'. For and on behalf of:

Company Date
Address
E Mail Tel. No.
Name (block capitals please) Signed

Point of Installation

To ensure the Washer Disinfector is delivered to the actual 'Point of Installation', please add below any special delivery instructions (block capitals please).

Contact Name Room No.
Department Floor Open Hours
Address (if different from above)

When these services have been installed and the site preparation has been completed, the Customer must take a copy of this completed certificate and send it to Eschmann by post or email.

Address: Eschmann Technologies Limited, Eschmann House, 15 Peter Road, Lancing, West Sussex, BN15 8TJ, UK

Email: sales@eschmann.co.uk

1. Choosing a Location

1.1. Requirements

Accessibility

There must be easy access to the room, and to the final location of the unit.

A minimum clearance of 65cm is required through doorways (a standard household doorway provides this).

Washer Disinfector Housing

Built-under

It can be installed under a continuous worktop or sink drainer.

The recess must be at least 620mm wide, 600mm deep and 840mm high*.

Noise level built-under : <70dB (A)

Freestanding, slot-in, or at the end of a row

It can be installed next to other machines or furniture, or in a suitable location.

The location must be at least 620mm wide and 600mm deep.

Noise level built-under : <70dB (A)

* If the height under the worktop is less than 840mm, Eschmann can, at installation, remove the top cover, thereby allowing the unit to fit into a minimum recess height of 835mm. Please contact Eschmann prior to installation as this will incur further charge.

Usable Empty Space

Provide a space or cupboard next to the unit at least 400mm wide for all the electrics and pipework.

1.2. Considerations

- Furniture and fittings installed near the unit must be of a commercial standard, able to withstand the effects of steam and condensed water.
- Do not site the unit under a fire or smoke alarm as the steam released from the cabinet after each cycle can trigger the alarm. A minimum of 3 metres from the unit is a safe distance for any smoke or fire alarm.
- Heat dissipation through heat radiation: 0.35kWh/h.
- Load heat dissipation on removal: 0.40kWh/h.
- The unit must sit level to operate correctly.
- To fit the Washer Disinfector into a cupboard, the installer will need to make cuts into the cupboard partition (refer to Fig 1). You will also require a neat hole in the worktop if you are fitting the Autolog or Printer above the worktop.
- The Washer Disinfector requires a separate drainage connection and is to be made from commercial grade waste pipe due to the temperatures exhausted down the waste.. This can be either:

An open drainage system: easy to fit stand-pipe, but may be susceptible to spillage in the case of a blocked drain.

A closed drainage system: requires a standard 22mm pipe run, but will prevent spillage in the case of a blocked drain.

- The unit requires two cold water supplies. A third RO/DI water supply is optional.
- It is important that you use only Eschmann approved and validated consumables/ test devices with this washer disinfector. Other consumables could be too aggressive resulting in damage to the washer disinfector or instruments and will not be validated to clean instruments effectively.

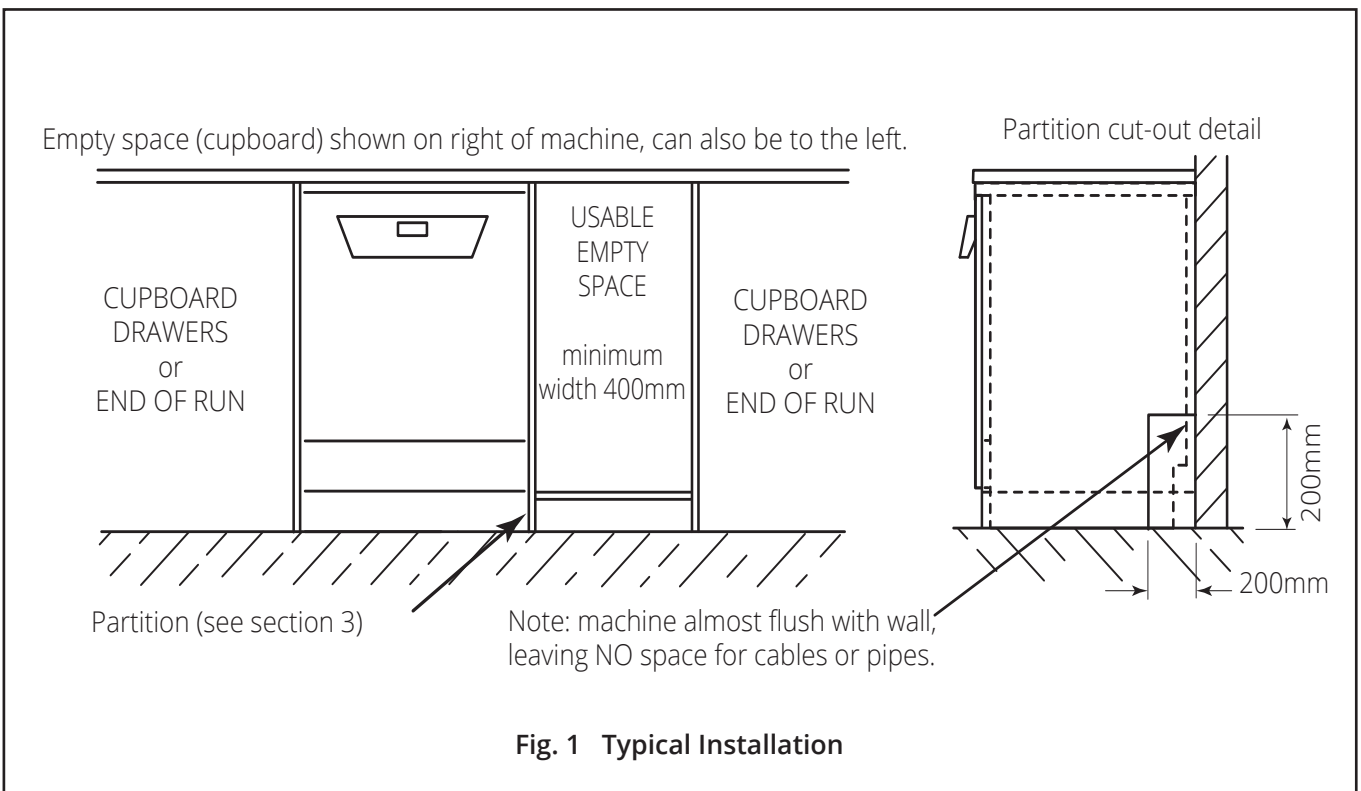

1.3. PG 8581

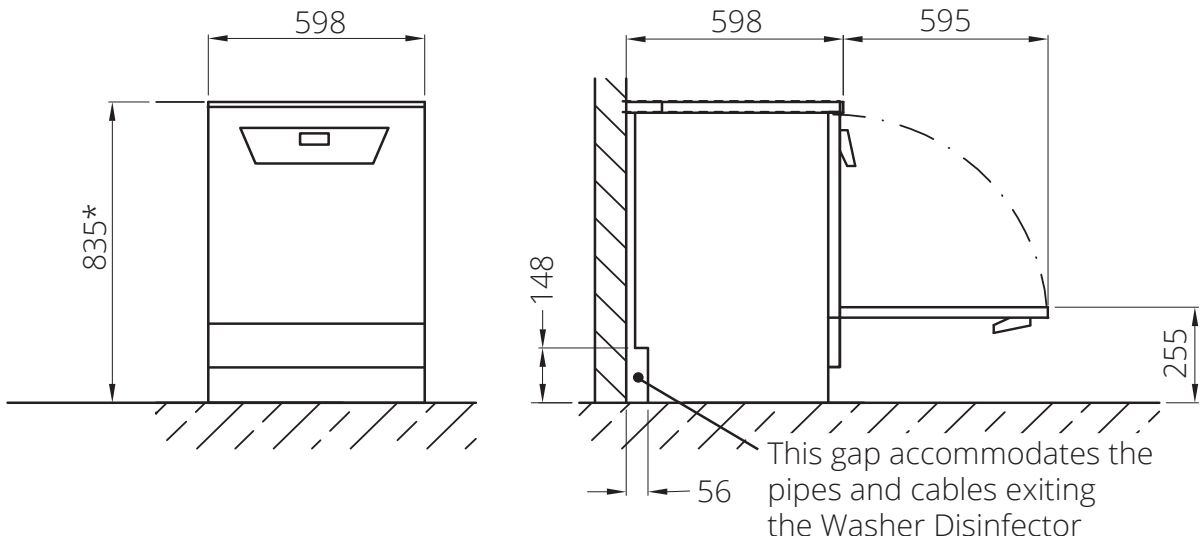

Fig. 2 Dimensions (mm)

2. Contractor Notes

PLEASE FOLLOW THE INSTRUCTIONS EXACTLY

It is very important that the site is prepared as detailed in this manual: placement, heights, components etc.

The installation will vary dependent upon:

- Mains drainage: closed or open system?
- Washer Disinfector electrical rating
- Is a Printer or Autolog to be fitted?

The contractor is to install the following items, as required by the installation:

- Mains electrical isolator
- Mains electrical socket
- Mains double socket
- Mains cold water supplies
- Mains drainage

Optional equipment (section 6):

- RO/DI Water supply
- Printer or Autolog

An Eschmann Service Engineer will fit:

- Mains electrical plug (connect to WD) **to be supplied by contractor**
- Container used with DOS
- Container for rinsing aid
- Non-return valve to mains water supply

2.1. Electrical Notes

- The unit MUST be earthed via a correctly installed earthing system.**
- We recommend that the supply incorporates a residual current device (normally located near the distribution board) with a trip current of 30mA.
- Hard-wiring the appliance to a wall socket is NOT acceptable as routine maintenance will be affected.
- Install a double, switched socket wired to the domestic supply. We recommend that it is a waterproof socket, although a "normal" socket may be used at the contractor's discretion.

2.2. Plumbing Notes

The mains water supply connection point must be easily accessible. Check that the minimum mains water pressure is not affected by other equipment using the same supply. The water pressure must never fall below the minimum 1.0 bar, 100 kPa, even under flow.

All pipework for (optional) RO/DI water must be made from plastic or stainless steel.

The unit requires one of the following separate drainage connections:

Open drainage system (standard option): fit a standard 40mm diameter waste pipe and waste trap, 300mm down from the worktop. This waste pipe should empty into the foul water sewer.

Closed drainage system: fit a standard 22mm copper pipe run, 300mm down from the worktop for any connector/adaptor fitted to the end of the pipe. This pipe should empty into the foul water sewer. At the Washer Disinfector end, point the pipe down and provide 30mm of pipe for Eschmann to connect to.

Connection to a sink trap is possible but this MUST be to the drain side, not the sink side. Call for advice.

The Eschmann Service Engineer will connect the Washer Disinfector's outlet hose to the drainage connection.

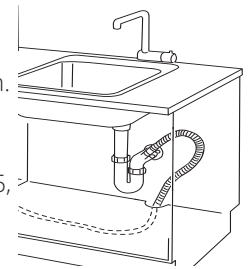

- A longer outlet hose can be supplied at extra cost where required (part number MS1545805, 2.25m). Do not use a hose longer than 4m.
- The drainage system beyond the connection point must be capable of draining up to 16 litres/minute.
- The waste water that drains could be up to 10 litres at 95°C for periods of up to 2 minutes every 45 minutes.
- The unit is fitted internally with a non-return valve which prevents dirty water from flowing back into the Washer Disinfector via the drain hose.
- The site's waste pipe must be of commercial grade due to temperatures of up to 95°C. (Recommended material, Vulcathene).

Do not install the Washer Disinfector in an area where a danger of explosion or freezing conditions may be present.

This equipment is not designed for maritime use or for use in mobile installations such as caravans, aircraft etc. However, it may be suitable for such usage subject to a risk assessment of the installation being carried out by a suitably qualified engineer.

Ratification: Water Regulations Advice Scheme (WRAS) Fluid Category 5 - Type AB Air Gap and Double Check Valve (back-flow prevention devices). WRAS approval: contact Eschmann for up-to-date certificate.

3. PG 8581: 32A 230V Single Phase Installation

Figure dimensions are in millimetres.

Read the Contractor Notes, section 2

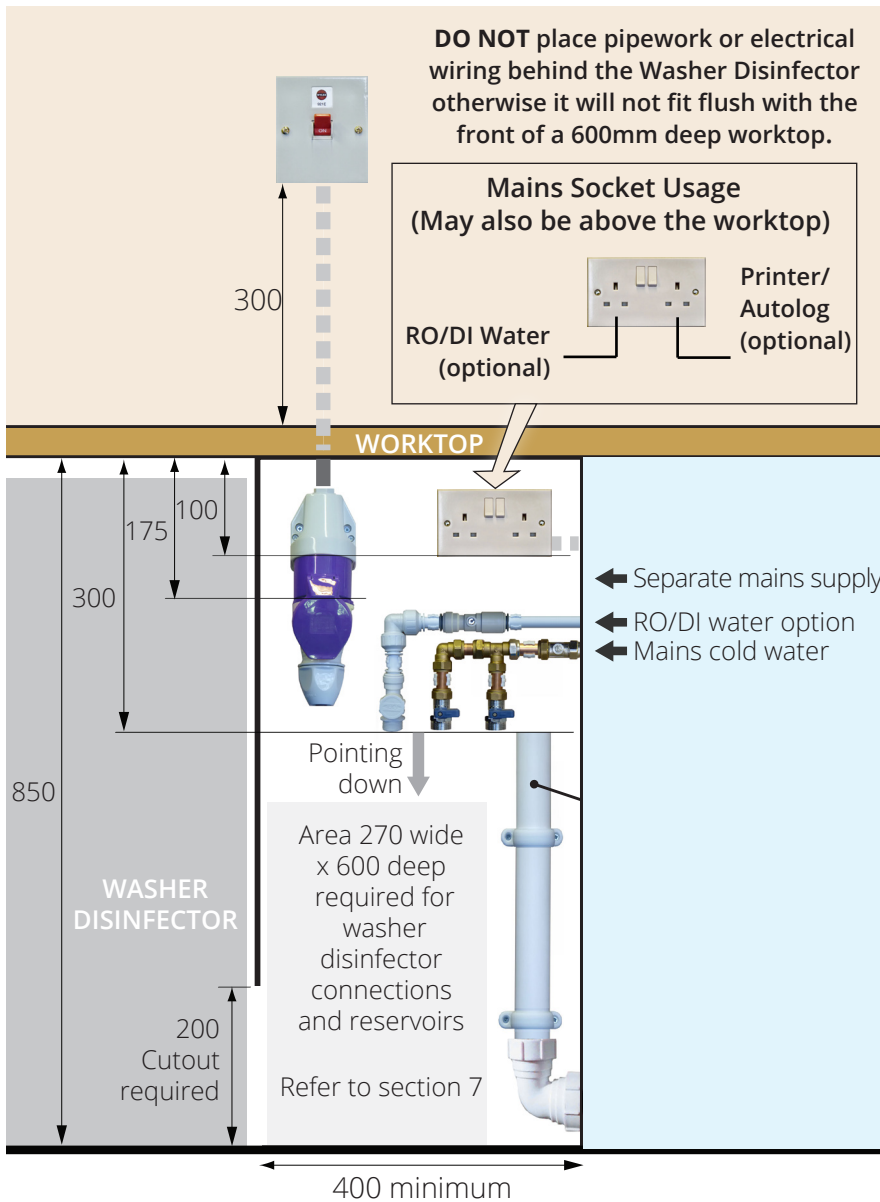

Electrical	
Supply Voltage	230Vac (±10%)
Fuse Rating	30A (Distribution board)
Rated Load	6.3kW
WD Mains Cable	2.0m with plug
Water Supply and Drainage	
Cold Water Pressure	1 - 10 bar (100 - 1000kPa)
Cold Water Supply	3/4" BSP (washing machine valve)
Inlet Hoses	3/4" BSP, 1.7m
Drain Hose	1.4m
Drainage Length (to down pipe)	4m maximum
RO/DI-water connection (optional extra)	1.5 - 10 bar (150 - 1000kPa) (Pipework must be plastic or stainless steel)
RO	3/4" BSP
Drain flow	16 litres/min maximum
Drain Temperature	Up to 95°C (use commercial grade waste pipe)
Weight (net)	74kg

Note: Do not position a fire/smoke alarm within 3 metres of this unit.

Parts for 32A single phase installation that may be required, as determined by the site contractor	
Key	Contents
	Double mains switched socket, surface mount, 13A 230V, and also the 2-Gang Surface Mount Back Box - 28mm deep
	Straight machine tap, quarter turn (Washing machine type) 15mm pipe to 3/4BSP male
	Plastic Speedfit (15mm) tap 3/4" BSP (15mm) Pipe (For RO/DI option)
	32A 230-400V Socket, single phase+N+E industrial, blue 32A 230-400V Plug, single phase+N+E industrial, blue. Eschmann part No. 111917.
	32A 230-400V Isolator Switch 3P+N+E

4. PG 8581: 400V 3-Phase Installation

Figure dimensions are in millimetres.

Read the Contractor Notes, section 2

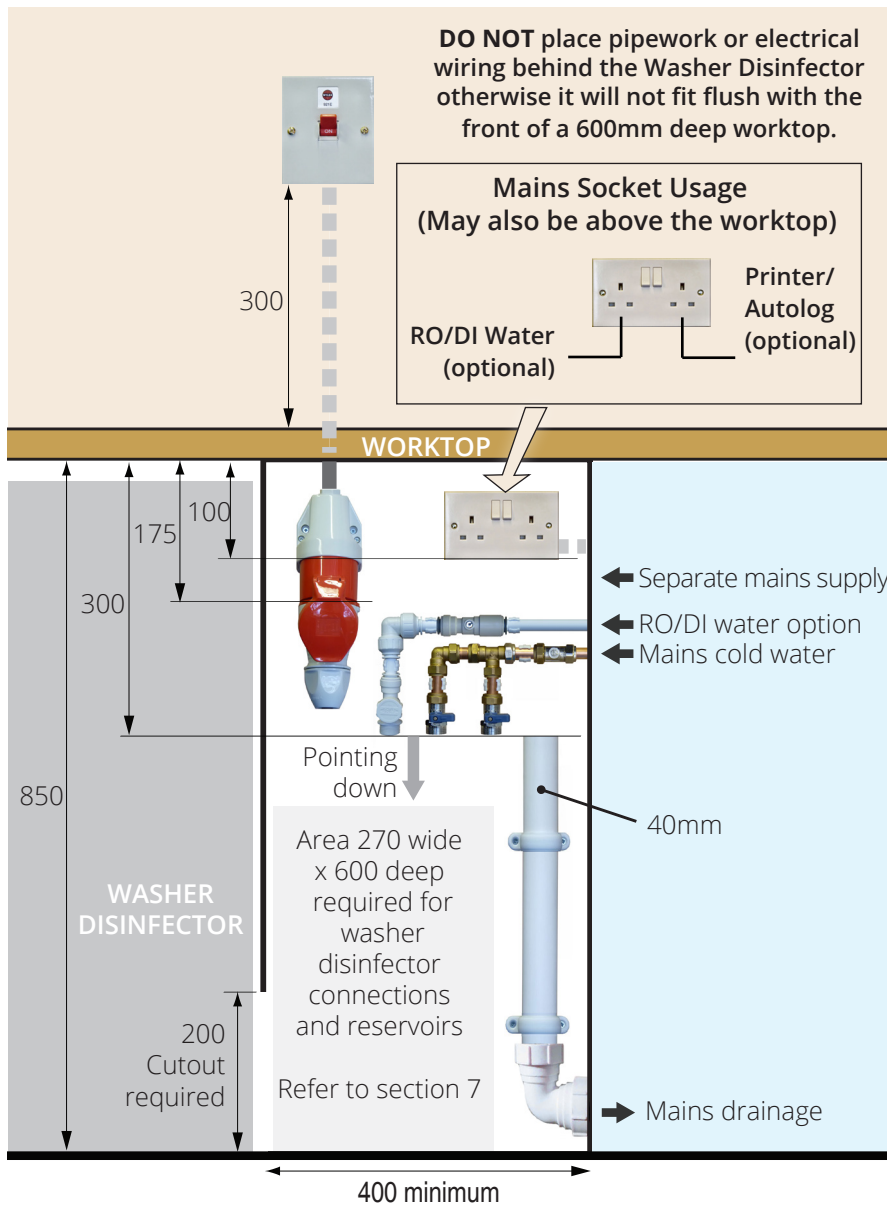

Electrical	
Supply Voltage	400Vac (±10%) 3P+N+E
Fuse Rating	3 x 16A (Distribution board)
Rated Load	9.7kW
WD Mains Cable	1.7m with plug
Water Supply and Drainage	
Cold Water Pressure	1 - 10 bar (100 - 1000kPa)
Cold Water Supply	3/4" BSP (Washing machine valve)
Inlet Hose	3/4" BSP, 1.5m
Drain Hose	1.5m
Drainage Length (to down pipe)	4m maximum
RO/DI-water connection (optional extra)	1.5 - 10 bar (150 - 1000kPa) (Pipework must be plastic or stainless steel)
RO	3/4" BSP
Drain flow	16 litres/min maximum
Drain Temperature	Up to 95°C (use commercial grade waste pipe)
Weight (net)	74kg

Note: Do not position a fire/smoke alarm within 3 metres of this unit.

Parts for 3-phase installation that may be required, as determined by the site contractor	
Key	Contents
	Double mains switched socket, surface mount, 13A 230V, and also the 2-Gang Surface Mount Back Box - 28mm deep
	Straight machine tap, quarter turn (washing machine type) 15mm pipe to 3/4BSP male
	Plastic Speedfit (15mm) tap 3/4" BSP (15mm) Pipe (for RO/DI option)
	32A per phase 380-415V Socket, 3P+N+E industrial, red 32A per phase 380-415V Plug, 3P+N+E industrial, red. Eschmann part No. 111918.
	32A 400V Isolator Switch 3P+N+E
	3-phase case 1.7m long cable with plug fitted. Eschmann part No. MS4904311

5. Optional Equipment

5.1. Autolog (8701027)

Eschmann can supply and fit the RS232 Autolog during installation.

The Autolog requires a standard domestic mains socket for power. It connects to the Washer Disinfector via an RS232 cable connected to a socket at the rear of the Washer Disinfector.



If the Autolog is to be situated in the cupboard with other services, then the connecting cables can go through the partition cut-out. A mains socket will be required under the worktop.

If the Autolog is to be situated on the worktop above the Washer Disinfector, then a hole for the connecting cables may be required through the worktop and any cupboard panels. Position a 12.7mm (1/2") diameter hole close to the back wall. A mains socket will be required above the worktop.

5.2. RS232 Printer (8721367)

Eschmann can supply and fit this optional RS232 printer during installation.

The Printer requires a standard domestic mains socket for power. It connects to the Washer Disinfector via an RS232 cable connected to a socket at the rear of the Washer Disinfector.



If the printer is to be situated in the cupboard with other services then the connecting cables can go through the partition cut-out. A mains socket will be required under the worktop.

If the printer is to be situated on the worktop above the Washer Disinfector then a hole for the connecting cables may be required through the worktop and any cupboard panels. Position a 12.7mm (1/2") diameter hole close to the back wall. A mains socket will be required above the worktop.

5.3. Eschmann RO Water System

Eschmann can supply an RO System with UV (8785154UVCSHW).

In addition, we can supply a WD Adaption Kit (8785513), which has a larger tank to increase water capacity.

For further information, contact Eschmann.



5.4. RO/DI Water Supply (Third party system)

RO/DI Requirement for Thermal Disinfection/ Final Rinse (Not the entire cycle)

The Site Preparation Installation parts detailed in Sections 3 and 4. Include the Plastic Speedfit tap required for this installation.

Note: Please discuss the pipework and positioning requirements for the RO plant with your RO supplier.

The RO/DI module must be specified and ordered independently.

The Reverse Osmosis or De-Ionised (RO/DI) water supply is an optional feature. It supplies filtered water for rinsing purposes to the Washer Disinfector.

Your RO/DI module must have the following specification:

1. Delivery rate: 10 litres per minute (5 litres per minute **minimum**)
2. Volume of water required: 12 litres per hour **minimum**
3. A constant delivery pressure of 1.5 barg **minimum** at all times during filling (maximum 10 barg)
4. A pressurised system
5. A suitable backflow prevention device for the Category 5 fluid processed by this WD

We don't know the dimensions of your RO/DI module, but it will probably need to be sited outside of the cupboard/space and in the close vicinity. Generally the independent RO/DI water system needs to have a pumped supply to the Washer Disinfector to provide a constant pressure of 1.5 barg.

The requirements for the unit are:

1. The RO/DI module requires a separate mains cold water supply waste connection, and mains electricity.
2. Provide a water supply pipe from the RO/DI module to the Washer Disinfector site. This pipework must NOT be copper. It could be plastic or stainless steel, to terminate in a 3/4" BSPP connection to connect to the RO port on the WD unit. Confirm with your RO supplier. House the connection in an area next to the Washer Disinfector (refer to section 3). DO NOT place pipework or electrical wiring behind the Washer Disinfector.
3. The Site Preparation Installation parts detailed in Sections 3 and 4 contain a plastic washing machine tap for the final connection to the Washer Disinfector.
4. The RO/DI module chosen is to incorporate a Back-Flow Prevention device Type A Air Gap for Cat 5 compliance: suggest Type AA, AB, or AD Air Gap, in line with BS EN1717.

When installing the Washer Disinfector, the Eschmann Service Engineer will reprogram the Washer Disinfector to accept the RO/DI module option.

6. Containers

6.1. Rinsing Aid

CONTRACTOR TO ALLOW SPACE PLEASE

**RINSING AID CONTAINER TO BE INSTALLED BY
ESCHMANN**

The rinsing aid container is a standard feature of the Washer Disinfector and is used to dose rinse aid automatically into the unit. It is supplied with the Washer Disinfector and will be installed by the Eschmann Service Engineer.

The container requires no services.

It is one of two containers that space must be provided for on site (Refer to section 3). Good access is required to the container to enable easy replacement. Connect the suction pipe from the washer disinfector that is marked RED.

The rinsing aid container is 245x145x225mm (LxWxH), 5 litre capacity.

6.2. Detergent

CONTRACTOR TO ALLOW SPACE PLEASE

**DETERGENT CONTAINER TO BE INSTALLED BY
ESCHMANN**

The detergent container is a standard feature of the Washer Disinfector and is used to dose detergent automatically into the unit. It is supplied with the Washer Disinfector and will be installed by the Eschmann Service Engineer.

The container requires no services.

It is one of two containers that space must be provided for on site (Refer to section 3). Good access is required to the container to enable easy replacement. Connect the suction pipe from the washer disinfector that is marked BLUE.

The detergent container is 245x145x225mm (LxWxH), 5 litre capacity.

Service

Eschmann products are supported by a network of fully trained engineers, offering high quality Eschmann spare parts. For further information on the range of Service Contracts available, please contact your local Eschmann representative.

Eschmann can be contacted during normal office hours. Please quote the model and serial number exactly as printed on the product label. Please use the contact details below.

Warranty

This product and purchased accessories are warranted for a minimum period of 12 months to be free from defects in materials and workmanship at the time of delivery.

Eschmann will be under no liability for any defect arising from fair wear and tear, negligence, wilful damage, misuse, abnormal working conditions, failure to follow the manufacturer's instructions, unauthorised alteration or repair of hardware, unauthorised or accidental alteration of software or configuration, lost profits, commercial loss, economic loss, or loss arising from personal injury. We may, at our discretion, raise a charge for any faults repaired that fall outside the warranty cover. Where charges are necessary, replacement parts will be charged at manufacturers' list prices and labour will be charged at the prevailing hourly rate. Repairs performed by Eschmann carry a 3-month parts and labour warranty.

The details in this manual are correct at time of going to press and supersede details previously published elsewhere. Information, technical specifications and statements made in this publication may be subject to change without prior notice.

Trade Marks

The Eschmann name and Logo are trade marks of Eschmann Technologies Limited. Eschmann Equipment is a trading name of Eschmann Technologies Limited.

Copyright © 2024 Eschmann Technologies Limited.

All rights reserved. This booklet is protected by copyright. No part of it may be reproduced, stored in a retrieval system or transmitted in any form or by any means, electronic, mechanical, photocopying, recording or otherwise, without written permission from Eschmann Technologies Limited.

The information in this publication was correct at the time of going to print. The Company reserves the right to modify or improve the product referred to.

Eschmann Technologies Limited

Eschmann House, 15 Peter Road, Lancing,
West Sussex, BN15 8TJ United Kingdom

t: +44 (0)1903 753322

e: info@eschmann.co.uk

w: eschmann.co.uk

Ingenuity in
infection control
since 1830

