

Ingenuity in
infection control
since 1830



C61 WD Washer Disinfector

Site Preparation Plan

Important: Please complete the Site Preparation Statement inside this manual to begin your washer disinfector installation.

Thank you for choosing Eschmann.

Eschmann design, manufacture and supply a range of market leading products including benchtop autoclaves, washer disinfectors, suction units and accessories.

For further information visit our website: www.eschmann.co.uk

About this Manual

Please read this Site Preparation Plan before installing or using the product for the first time. Keep the manual handy for quick reference. Always make sure that the manual is available for the next user/owner of the product.

The product(s) described in this manual must only be operated and used by medically qualified personnel trained in the use of this equipment. Contact Eschmann with your training requirements.

Pay particular attention to the safety notes, cautions and warnings provided in the text, and also to those displayed on the product labels.

This product must be used, installed and serviced in accordance with the procedures given in this manual. Failure to do so could result in injury to patients and/or users, or damage to the equipment.

Confirm the service interval for the product. Eschmann products must be serviced and maintained by Eschmann trained engineers only. Failure to do so may invalidate the warranty.

Contents

Site Preparation Statement	5
1 Choosing a Location	6
1.1 Requirements	6
1.2 Considerations	6
2 Contractor Notes	7
2.1 Electrical Notes	7
2.2 Plumbing Notes	7
3 Installation	8
4 Optional Equipment	9
4.1 Autolog (8701027)	9
4.2 RS232 Printer (8721367)	9
4.3 Eschmann RO Water System	9
4.4 RO/DI Water Supply (third party system)	9

What To Do

Prepare the installation site to meet ALL of the requirements in this manual.

- 1** Read and understand this manual. Obtain technical advice if required.

If there are problems with the site preparation or the site services, an engineer's visit will be charged at the normal rate.

- 2** Provide a cupboard or space next to the unit for all the electrics and pipe work. **Sections 1 and 3**

Read Sections 1 and 3 for the minimum width required.

- 3** Ask your contractor to source the necessary site termination, as detailed in Section 3. **Section 3**

- 4** Before the contractors start work, tell them about any options being fitted:

 - RO/DI (Reverse Osmosis or De-Ionised) water supply, or other specialist water supply (requires extra water and electrical supplies) **Section 4**
 - Printer or Autolog

- 5** The contractors must follow the plans **exactly** and install:

 - Electrical supplies and power points
 - A mains cold water supply
 - A separate water drainage connection point
 - Optional separate RO/DI water supply connection point
 - Prepare all cut-outs and holes in work tops and cupboards as required**Sections 2, 3 & 4**

- 6** When you are sure that the site is ready, you and your contractor(s) MUST sign the **Site Preparation Statement** and send it to Eschmann.

On receipt of the certificate, we'll arrange a mutual date to install your Washer Disinfector. We'll also send you a free sample of the recommended detergent to use during installation.

WARNING!

All electrical and plumbing work must be carried out by suitably qualified and competent persons in accordance with local and national safety regulations.

We recommend using a WRAS approved plumber (Water Regulations Advice Scheme). Visit their website "www.wras.co.uk" for details.

We recommend using an NICEIC approved electrician. Visit their website "www.niceic.org.uk" for details.

CAUTION

This Washer Disinfector should only be installed and maintained by an Eschmann Service Engineer. Repairs and other work by unqualified persons could be dangerous.

Site Preparation Statement

The site preparation has now been completed in accordance with the 'Site Preparation Plan' reference UW200201. Please make arrangements to Install the Washer Disinfector on a mutually agreeable time and date. Contact details have been entered below. I am aware that should the site preparation not be to the required standard, or is in any way not suitable for installing the Washer Disinfector upon the arrival of the Eschmann Service Engineer, I will be liable for the standard cost of an Engineer's call out charge. By signing this certificate below I am accepting this charge should it be incurred.

Electrical site preparation (To be signed by Electrical Contractor)

I hereby certify that the electrical site preparation for the Washer Disinfector has been carried out in accordance with the 'Site Preparation Plan' reference 200201. I also certify that all the site installation work complies with all National and Local Legislation current at the time the work was carried out. For and on behalf of:

Company Date
Address
.....
Email Tel. No.
Name (Block capitals please) Signed

Plumbing site preparation (To be signed by Plumbing Contractor)

I hereby certify that the plumbing site preparation for the Washer Disinfector has been carried out in accordance with the 'Site Preparation Plan' reference 200201. I also certify that all the plumbing complies with all National and Local Legislation current at the time the work was carried out. For and on behalf of:

Company Date
Address
.....
Email Tel. No.
Name (Block capitals please) Signed

Site preparation approval (To be signed by the Customer)

I hereby certify that the plumbing, electrics and partition cut-out as detailed in Section 1 for the Washer Disinfector has been carried out in accordance with the 'Site Preparation Plan' reference 200201 and that the site is suitable for the installation and commissioning of the Washer Disinfector. I have read the Eschmann Guarantee in section 5 of the 'Site Preparation Plan'. For and on behalf of:

Company Date
Address
.....
E Mail Tel. No.
Name (Block capitals please) Signed

Point of Installation

To ensure the Washer Disinfector is delivered to the actual 'Point of Installation', please add below any special delivery instructions (block capitals please).

Contact Name Room No.
Department Floor Open Hours
Address (if different from above)
.....

When these services have been installed and the site preparation has been completed, the customer must take a copy of this completed certificate and post it to:

**Eschmann Technologies Limited, Eschmann House,
15 Peter Road, Lancing, West Sussex BN15 8TJ.**

1. Choosing a Location

Requirements

Accessibility

There must be easy access to the room, and to the final location of the unit.

Location

It can be installed on a stable, fixed worktop at waist height that is at least 700mm wide and 575mm deep.

Noise level : <65dB (A)

Electrical Supplies

Electrical supplies for the unit must be accessible, close by, and sited above the worktop.

Water Supplies

Water supplies and drainage for the unit can be sited above the worktop directly behind the unit, or sited in a cupboard or space underneath the unit.

- To fit the Washer Disinfector, the site contractor will need to make a cut into the worktop (see below). This is for the water supply and drain hoses.

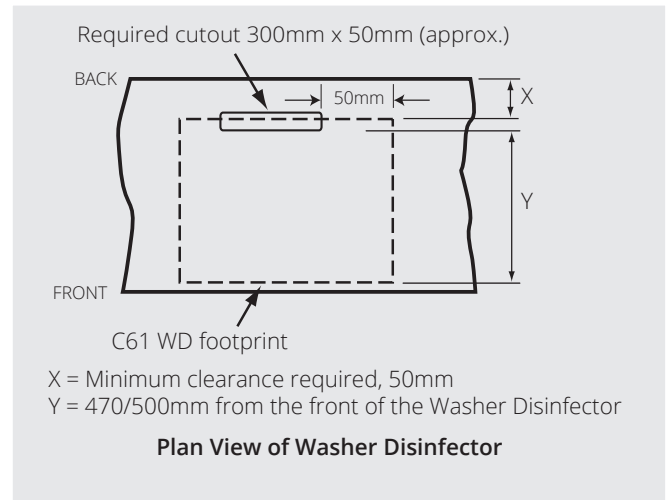

Considerations

- Furniture and fittings installed near the unit must be of a commercial standard, able to withstand the effects of steam and condensed water.
- Do not site the unit under a fire or smoke alarm as the steam released from the cabinet after each cycle can trigger the alarm. A minimum of 3 metres from the unit is a safe distance for any smoke or fire alarm.
- The unit must sit level to operate correctly.

- The Washer Disinfector requires a separate drainage connection and is to be made from commercial grade waste pipe due to the temperatures exhausted down the waste:

An open drainage system: easy to fit stand-pipe, but may be susceptible to spillage in the case of a blocked drain.

- The unit requires two cold water supplies; or one hot and one cold water supply. A third RO/DI water supply is optional.
- It is important that you use only Eschmann approved consumables with this washer disinfector. Other products could be too aggressive resulting in damage to the washer disinfector or instruments.

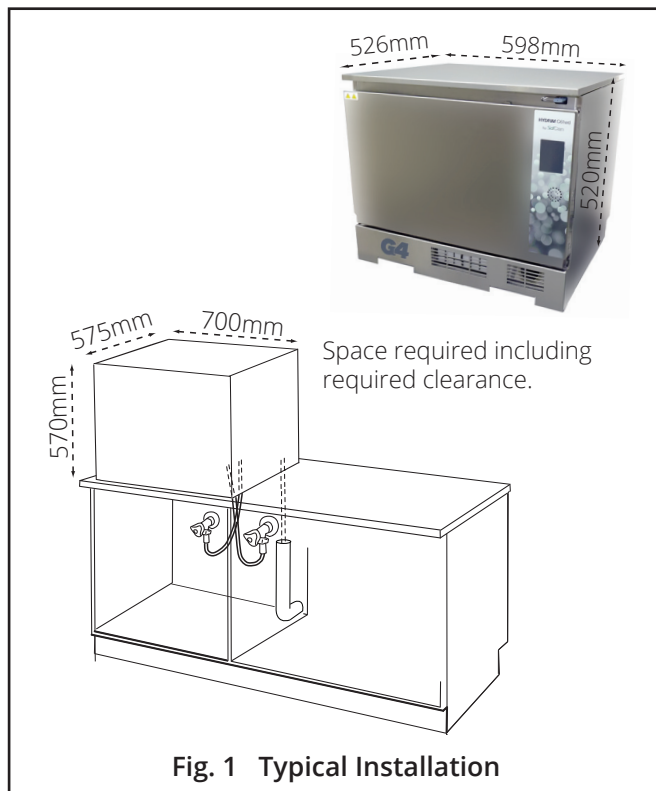

2. Contractor Notes

PLEASE FOLLOW THE INSTRUCTIONS EXACTLY

It is very important that the site is prepared as detailed in this manual: Placement, heights, components etc.

The installation will vary dependent upon:

Is the pipework to be sited above the worktop directly behind the unit, or sited in a cupboard or space underneath the unit?

Is a printer or Autolog to be fitted?

Is an RO/DI water supply required?

The contractor is to install the following items, as required by the installation:

Mains electrical switched socket

Mains cold water supply

Hot water (or second cold water) supply

Mains drainage

Optional equipment:

Printer or Autolog

RO/DI water supply

2.1. Electrical Notes

- **The unit MUST be earthed via a correctly installed earthing system.**
- We recommend that the supply incorporates a residual current device (normally located near the distribution board) with a trip current of 30mA.
- Hard-wiring the appliance to a wall socket is NOT acceptable as routine maintenance will be affected.
- Install a switched socket wired to the domestic supply. If a printer or Autologger is to be fitted, please make this a double socket. If the socket is not switched, fit a mains electrical isolator close by for the socket.
- There must be a switch to isolate the electrical supply from the washer disinfectant. If the mains socket (single or double) is not switched, then an isolator must be fitted.
- The electrical socket must be at least 0.5 metres away from the water connections for the unit.

2.2. Plumbing Notes

The mains water supply connection point must be easily accessible. Make the worktop cut-out shown on page 6.

Check that the minimum mains water pressure is not affected by other equipment using the same supply. The water pressures for hot and cold water supplies must never fall below the minimum 1.0 Barg. Check that this minimum pressure is not affected by other equipment using the same supply.

If at any time the pressure is greater than 10 Bar (1000kPa) then a pressure reducer must be fitted.

The Eschmann Engineer will fit a double check valve (Type ED) to the mains potable water supply when installing the Washer Disinfectant.

The unit requires a separate drainage connection:

Open drainage system: Fit a standard 32mm diameter waste pipe and waste trap, 300mm down from the worktop. This waste pipe should empty into the foul water sewer.

Eschmann recommend fitting a HepVO Self Sealing Waste Valve. Refer to details in Section 3.

The Eschmann Service Engineer will connect the Washer Disinfectant's outlet hose to the drainage connection.

- The drainage system beyond the connection point must be capable of draining up to 16 litres/minute at temperatures of up to 95°C. We recommend commercial grade waste pipe due to the temperatures exhausted down the waste.
- The unit is fitted internally with a non-return valve which prevents dirty water from flowing back into the Washer Disinfectant via the drain hose.

Do not install the Washer Disinfectant in an area where a danger of explosion or freezing conditions may be present.

This equipment is not designed for maritime use or for use in mobile installations such as caravans, aircraft etc. However, it may be suitable for such usage subject to a risk assessment of the installation being carried out by a suitably qualified engineer.

Test Marks

EN 5883-1 : 2006

EN 15883-2 : 2006

The Type AB Air Gap is in line with BS EN 1717: 2000.

3. C61 WD Installation

Read the Contractor Notes, Section 2

Figure dimensions are in millimetres.

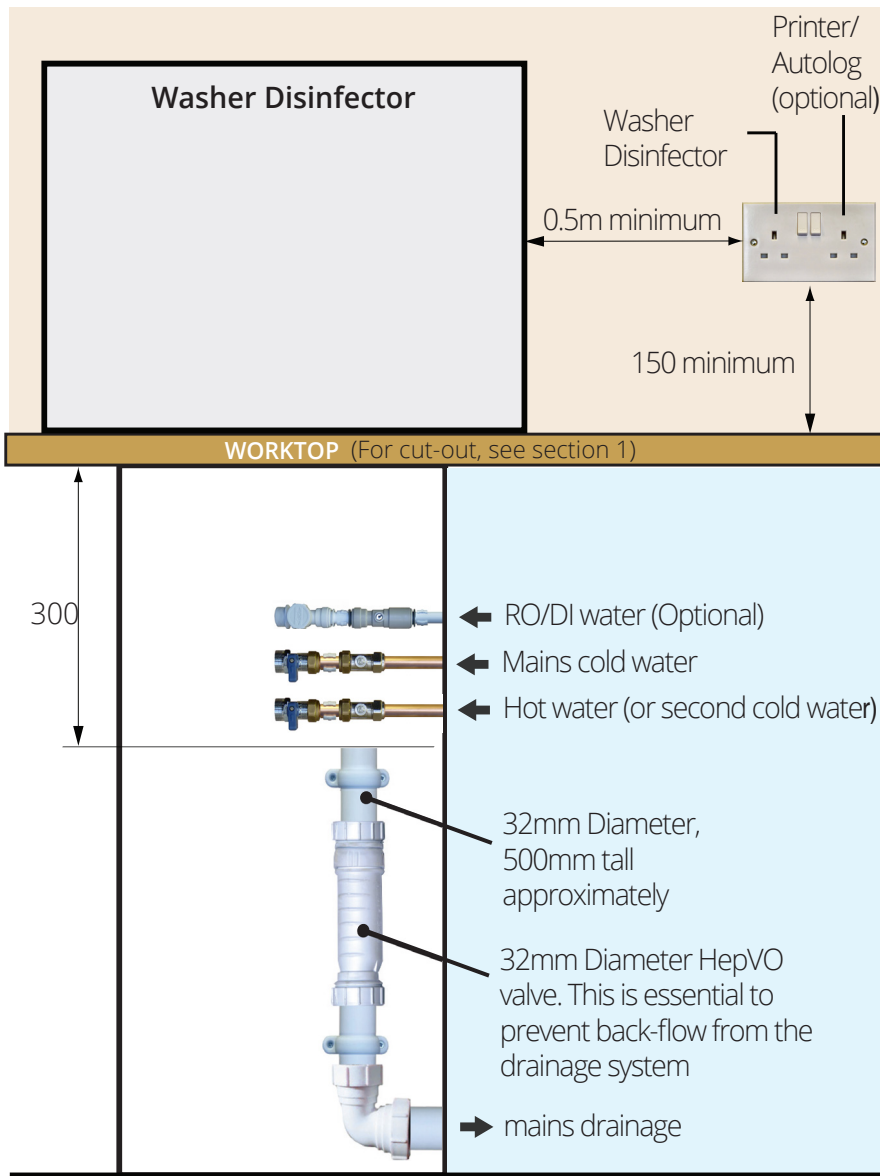

Refer to Section 4 for RO Requirements when required by the customer.

Electrical	
Supply Voltage	230Vac ±10%
Fuse Rating	13A
Rated Load	2.7kW
WD Mains Cable	2m with plug
Water Supply and Drainage	
Inlet Water Pressure	1 - 10 barg (100 - 1000kPa)
Cold & Hot Water Supply	¾" BSP (washing machine valve)
Inlet Hose	¾" BSP, 1.5m
Drain Hose	1.6m
Drainage Length (to down pipe)	3.3m maximum
Drainage Head	1m maximum
Drainage Rate	Maximum rate 16 litres/min
Drain Temperature	Maximum 95°C
Miscellaneous	
Weight	44kg
Maximum Relative Humidity	80% up to 31°C 50% up to 40°C
Operating Temperature Range	5°C to 40°C
Maximum Altitude	2000m
Ventilation Clearance	50mm on both sides, top, and rear of unit

C61 WD Site Preparation Parts That May be Required As Determined by the Site Contractor	
Key	Contents
	Double mains switched socket, surface mount, 13A 230V and also the 2-Gang Surface Mount Back Box - 28mm deep
	Straight machine tap, quarter turn (washing machine type) and 15mm pipe to 3/4BSP male
	Plastic Speedfit (15mm) tap 3/4" BSP (15mm) Pipe (for RO/DI option)
	HepVO Self Sealing Waste Valve (32mm) HepVO Straight Adaptor (32mm) - for above

4. Optional Equipment

4.1. Autolog (8701027)

Eschmann can supply and fit the RS232 Autolog during installation.

The Autolog requires a standard domestic mains socket for power. It connects to the Washer Disinfector via an RS232 cable connected to a socket at the rear of the Washer Disinfector.

The AutoLog should be positioned on top of the C61WD. The mains socket identified in Section 3 should be used.



4.2. RS232 Printer (8721367)

Eschmann can supply and fit this optional RS232 printer during installation.

The Printer requires a standard domestic mains socket for power. It connects to the Washer Disinfector via an RS232 cable connected to a socket at the rear of the Washer Disinfector.

The Printer should be positioned on top of the C61WD. The mains socket identified in Section 3 should be used.



4.3. Eschmann RO Water System

Eschmann can supply an RO System with UV (8785154UVCSHW).

In addition, we can supply a WD Adaption Kit (8785513) which has a larger tank to improve water capacity requirements.

For further information contact Eschmann.

4.4. RO/DI Water Supply (Third party system)

RO/DI Requirement for Thermal Disinfection/ Final Rinse (Not the entire cycle)

The Site Preparation Installation parts detailed in Section 3 include the Plastic Speedfit tap and plastic pipework required for this installation.

Note: Please discuss the pipework and positioning requirements for the RO plant with your RO supplier.

The RO/DI module must be specified and ordered independently.

The Reverse Osmosis or De-Ionised (RO/DI) water supply is an optional feature. It supplies filtered water for rinsing purposes to the Washer Disinfector.

Your RO/DI module must have the following specification:

1. Delivery rate: 10 litres per minute (5 litres per minute **minimum**)
2. Volume of water required: 6 litres per hour **minimum**
3. A constant delivery pressure of 1.5 barg **minimum** at all times during filling (maximum 10 barg)
4. A pressurised system
5. A suitable backflow prevention device for the Category 5 fluid processed by this WD

We don't know the dimensions of your RO/DI module, but it will probably need to be sited outside of the cupboard/space and in the close vicinity. Generally the independent RO/DI water system needs to have a pumped supply to the Washer Disinfector to provide a constant pressure of 1.5 barg.

The requirements for the unit are:

1. The RO/DI module requires a separate mains cold water supply waste connection, and mains electricity.
2. Provide a water supply pipe from the RO/DI module to the Washer Disinfector site. This pipework must NOT be copper. It could be plastic or stainless steel, to terminate in a 3/4" BSP connection to connect to the RO port on the WD unit. Confirm with your RO supplier. House the connection in an area next to the Washer Disinfector (Refer to Section 3). DO NOT place pipework or electrical wiring behind the Washer Disinfector.
3. The Site Preparation Installation parts detailed in Section 3 identifies the recommended plastic fittings.
4. The RO/DI module chosen is to incorporate a Back-Flow Prevention device Type A Air Gap for Cat 5 compliance: suggest Type AA, AB, or AD Air Gap, in line with BS EN1717: 2000.

When installing the Washer Disinfector, the Eschmann Service Engineer will reprogram the Washer Disinfector to accept the RO/DI module option.

Service

Eschmann products are supported by a network of fully trained engineers, offering high quality Eschmann spare parts. For further information on the range of Service Contracts available, please contact your local Eschmann representative.

Eschmann can be contacted during normal office hours. Please quote the Model and identifying numbers (SN) exactly as printed on the product label. Address all Eschmann correspondence to:

Eschmann Technologies Limited, Eschmann House, 15 Peter Road, Lancing, West Sussex, BN15 8TJ, United Kingdom. Tel: +44 (0)1903 753322

Warranty

This product and purchased accessories are warranted for a minimum period of 12 months to be free from defects in materials and workmanship at the time of delivery.

The technical lifetime of the washer disinfectant is defined as 7 years.

Eschmann will be under no liability for any defect arising from fair wear and tear, negligence, wilful damage, misuse, abnormal working conditions, failure to follow the manufacturer's instructions, unauthorised alteration or repair of hardware, unauthorised or accidental alteration of software or configuration, lost profits, commercial loss, economic loss, or loss arising from personal injury. We may, at our discretion, raise a charge for any faults repaired that fall outside the warranty cover. Where charges are necessary, replacement parts will be charged at manufacturers' list prices and labour will be charged at the prevailing hourly rate. Repairs performed by Eschmann carry a 3-month parts and labour warranty.

Trade Marks

The Eschmann name and Logo are trade marks of Eschmann Technologies Limited. Eschmann Equipment is a trading name of Eschmann Technologies Limited.

Copyright © 2022 Eschmann Equipment

All rights reserved. This booklet is protected by copyright. No part of it may be reproduced, stored in a retrieval system or transmitted in any form or by any means, electronic, mechanical, photocopying, recording or otherwise, without written permission from Eschmann Technologies Limited.

The information in this publication was correct at the time of going to print.
The Company reserves the right to modify or improve the product referred to.

Eschmann Technologies Limited

Eschmann House, 15 Peter Road, Lancing,
West Sussex, BN15 8TJ United Kingdom

t: +44 (0)1903 753322

e: info@eschmann.co.uk

w: eschmann.co.uk

Ingenuity in
infection control
since 1830

